

# Cardiovascular Systems, Inc.

IMPROVING THE TREATMENT OF VASCULAR DISEASE WITH SOLIDWORKS



Using SolidWorks software, CSI is revolutionizing the treatment of vascular disease through the development of products like the PREDATOR 360, a disposable, diamond-coated catheter-based device.

## CHALLENGE:

Develop, commercialize, and manufacture clinically proven, safe, and effective medical devices for the treatment of vascular disease.

## SOLUTION:

Implement SolidWorks design, SolidWorks Simulation Premium analysis, and 3DVIA Composer technical communication software to accelerate development, streamline manufacturing, and garner regulatory approvals.

## RESULTS:

- Reduced development time by 25 percent
- Cut manufacturing costs by 20 percent
- Introduced effective treatment for removing arterial plaque
- Improved health and lifestyles of vascular disease patients

Vascular disease has become a major health problem for more than 17 million people. Whether the buildup of arterial plaque occurs in the extremities, known as peripheral arterial disease (PAD), or in the blood vessels surrounding the heart, known as coronary artery disease, it constricts the blood flow, threatens the health, and compromises the lifestyles of its victims. Angioplasty, the traditional treatment of the condition, which involves the use of a balloon on the end of a catheter to inflate blood vessels. However, this method is not always effective, particularly in removing the calcified plaque that is often the primary source of the problem.

Cardiovascular Systems, Inc. (CSI) is revolutionizing the treatment of vascular disease through the development of a disposable, diamond-coated catheter-based device. Utilizing the principle of centrifugal force, CSI's device orbits the interior wall of the artery at speeds of 200,000 revolutions per minute and grinds away up to 90 percent of the plaque creating the obstruction – a procedure known as orbital atherectomy. A new version of the Diamondback 360® OAD System, which is cleared by the federal Food and Drug Administration (FDA) for use in limb arteries, will begin clinical trials for the treatment of coronary artery disease in 2010.

Although the company used 2D design techniques to conceptualize the technology, commercializing CSI's products required a more capable 3D system, according to Christopher Narveson, design and engineering services manager. "CSI needed a 3D package to bring our technology to market because of the need to visualize and analyze design concepts, materials, and manufacturing techniques," Narveson recalls. "While 2D got us started, producing a viable commercial product demanded 3D."

*“We are also using 3DVIA Composer to create animations of new designs for consulting physicians to show how the product will inject, travel, and work.”*

**Christopher Narveson**  
Design and Engineering  
Services Manager

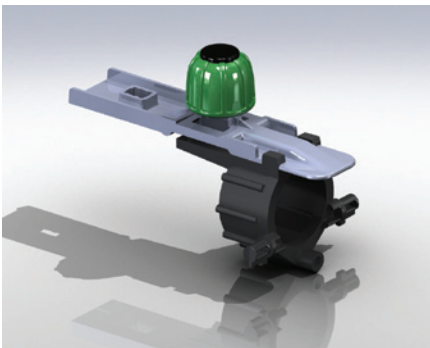
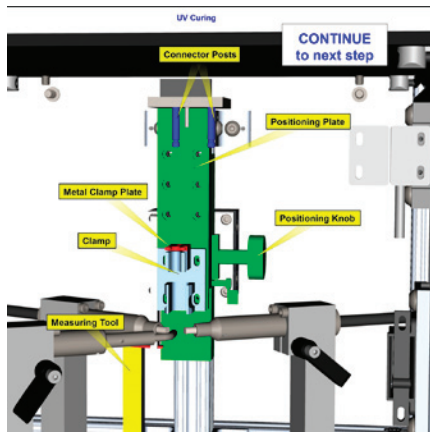

With 3DVIA Composer, the company's engineers created easy-to-follow assembly animations that run on a computer terminal inside the clean room, completely eliminating the sleeving and cleaning process.

After evaluating leading 3D design systems, CSI chose SolidWorks®, eventually implementing eight SolidWorks CAD licenses as well as additional seats of SolidWorks Simulation Premium analysis and 3DVIA Composer technical communication software. The company chose SolidWorks because of its ease of use, advanced manufacturability assessment tools, integrated simulation applications, and design communication solutions. “SolidWorks is a really strong package that provided the platform we needed to bring our products to market quickly and cost-effectively,” Narveson says.

### Design for manufacturability

The implementation of SolidWorks software has made a substantial impact on CSI's ability to accelerate development and control manufacturing costs. Using SolidWorks design for manufacturability tools – including DFMXpress, TolAnalyst™, and moldability analysis – the company cut its development time by 25 percent and the cost of manufacturing by 20 percent.

“SolidWorks not only allows us to create an elegant design that performs its intended function, but also enables us to manufacture parts in a way that holds down costs,” Narveson stresses. “We rely on SolidWorks design for manufacturability tools – such as using TolAnalyst to automate tolerance stackups and draft and wall thickness analysis, which enabled us to work with our suppliers to create high-precision injection molds – to ensure that we can manufacture and assemble products efficiently.”

### Simulating high-strength materials

While the orbital atherectomy devices that CSI used for its clinical trials were all steel, manufacturing disposable versions that follow FDA approval required an examination of less expensive materials. Using SolidWorks Simulation Premium software, the company's engineers were able to thoroughly analyze the blend of high-strength plastics they utilized to validate performance prior to testing.

“Because a doctor will use our device once and then throw it out, we needed to choose the most cost-effective materials without compromising performance,” Narveson points out. “With SolidWorks Simulation Premium software, we were able to conduct structural and fatigue analyses to optimize our design and material selection. This type of information was key to controlling costs, ensuring quality, and staying on schedule.”

### 3DVIA automates clean-room assembly

Through the addition of 3DVIA Composer technical communication software, CSI has the ability to automate its assembly operations. The company assembles its products in a Class 10,000 clean room. Before implementing 3DVIA Composer, clean room operators had to keep paper assembly instructions in plastic sleeves and swab the documents regularly with alcohol. With 3DVIA Composer, the company's engineers created easy-to-follow assembly animations that run on a computer terminal inside the clean room, completely eliminating the sleeving and cleaning process.

“The assembly animations that we created with 3DVIA Composer are an example of how 3D is helping us to streamline processes and save time,” Narveson notes. “We are also using 3DVIA to create animations of new designs for consulting physicians to show how the product will inject, travel, and work. 3D is vital for us, and 3DVIA Composer gives us the flexibility to use 3D in innovative ways.”



Dassault Systèmes SolidWorks Corp.  
300 Baker Avenue  
Concord, MA 01742 USA  
Phone: 1 800 693 9000  
Outside the US: +1 978 371 5011  
Email: info@solidworks.com  
www.solidworks.com



Cardiovascular Systems, Inc.  
651 Campus Drive  
St. Paul, MN 55112 USA  
Phone: +1 877 274 0360  
www.csi360.com  
VAR: Symmetry Solutions, Inc.,  
Minneapolis, Minnesota, USA